



14th International Conference on Greenhouse Gas Control Technologies, GHGT-14

21st -25th October 2018, Melbourne, Australia

Heat integration analysis and optimization for a post combustion CO₂ capture retrofit study of SaskPower's Shand power station

Stavroula Giannaris¹, Brent Jacobs¹, Wayuta Srisang¹, Corwyn Bruce¹,
Dominika Janowczyk¹

¹The International CCS Knowledge Centre, 198 – 10 Research Drive, Regina, Saskatchewan Canada S4S 7J7

Extended Abstract

Post combustion CO₂ capture processes require thermal energy (from steam) for amine regeneration. In coal-fired power stations, steam can be extracted from within the steam cycle – resulting in a power production penalty. Heat integration is the study of minimizing energy consumption while maximizing heat recovery; required for successful CCS retrofits. In October 2014, the World's First Integrated Carbon Capture Facility, SaskPower's Boundary Dam Unit 3 (BD3 ICCS), went on line. Various modifications to the turbine and feed heating system at BD3 contributed greatly to overall project costs (Figure 1).

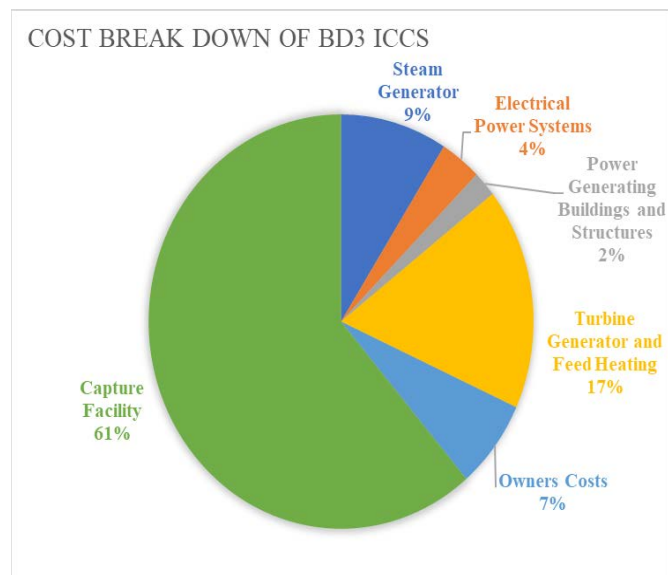

Figure 1. Cost Breakdown of BD3 ICCS

SaskPower's Shand Power Station is a 305 MW, single unit, coal-fired power plant producing approximately 1,100 kg of CO₂/MW-h. Shand's capacity is twice that of BD3's - an ideal candidate for a CCS scale up project. Heat integration analysis of the existing steam cycle at Shand was conducted using GateCycle™. A baseline model was built using Shand's Heat Balance and served as the design case. Configurations of steam extractions to the deaerator (DEA), extractions to the reboiler, and utilization of a flue gas cooler (FGC) working in conjunction with a condensate pre-heater (CPH) train were investigated. Optimization of steam extraction to the reboiler and configuration of the condensate preheating train were accomplished. Two cases were investigated: Case 1: 100% load and Case 2: 75% load.

Modelling the steam cycle with CCS on line entailed optimizing the steam extraction to the reboiler by sourcing it from the IP-LP Crossover

while also running the FGC and CPH train synchronously. An important modification was the addition of a butterfly valve in the IP-LP crossover (Figure 2). Changing the pressure at the back end of the IP turbine changes the pressure ratios within the last stages of the IP turbine, subsequently leading to volumetric flow rate changes (impacting turbine efficiency and stresses). Butterfly valves are used to maintain IP turbine back end pressure thus avoiding costly modifications to the turbine itself. In the intended design of Shand's steam cycle, the turbine was modified to not require a butterfly valve at full load thus the butterfly valve remains fully open at full load. Its inclusion provides design margin and the ability to run at off design conditions. At reduced loads the butterfly valve functions to supply steam at a high enough pressure to continue capture operations by throttling the flow of steam.

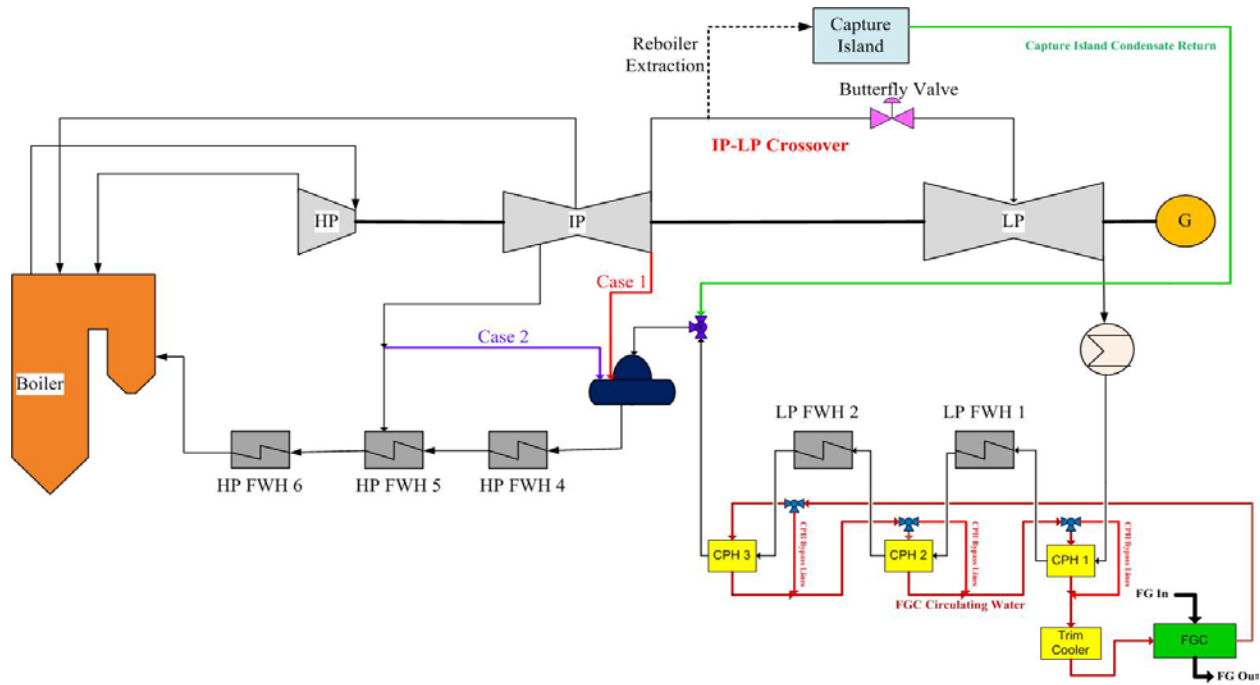

Figure 2. Steam Cycle Configurations for Reboiler and DEA Extractions and CPH

The steam for the DEA is sourced from the LP turbine limiting the quantity of condensate preheating possible and affecting performance. Alternate steam sources to the DEA were investigated. Each case was evaluated at 100% and 75% loads. Results are shown in Figure 3. The IP extraction to the DEA offers the least output penalty. *Case 1* was modelled to keep the current LP feed heating system and avoid replacement costs. The DEA pressure was set to its current design values for the 100% and 75% cases. The DEA extraction was taken from the IP exhaust. Using an iterative process, the maximum amount of condensate preheating was found assuming a minimum 15°C temperature rise between the temperatures of the condensate stream and the DEA. Case 2 was also modelled this way but with the

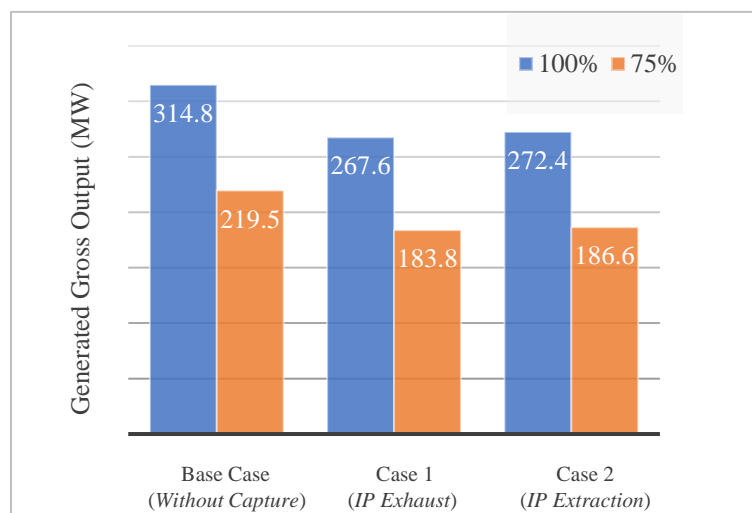

Figure 3. Gross Output Between Cases at 100% and 75% Loads for DEA Steam Extraction Investigation

extraction to the DEA from the IP to FWH5 extraction line. The extraction to the DEA from a higher-pressure steam source increases the operating pressure and temperature of the DEA which facilitates a greater extent of condensate preheating, better utilization of “waste” flue gas heat, and an overall decrease in the output penalty to the plant (Figure 4). This increased potential to utilize more heat from the flue gas for condensate preheating improves over all heat integration and increases overall output. Further increasing the DEA pressure to optimize the CPH loop would be limited by the design pressure of the DEA. Beyond this point economics would be considered in replacing the existing LP feed heating system to facilitate further increases to DEA pressure and utilization of the CPH.

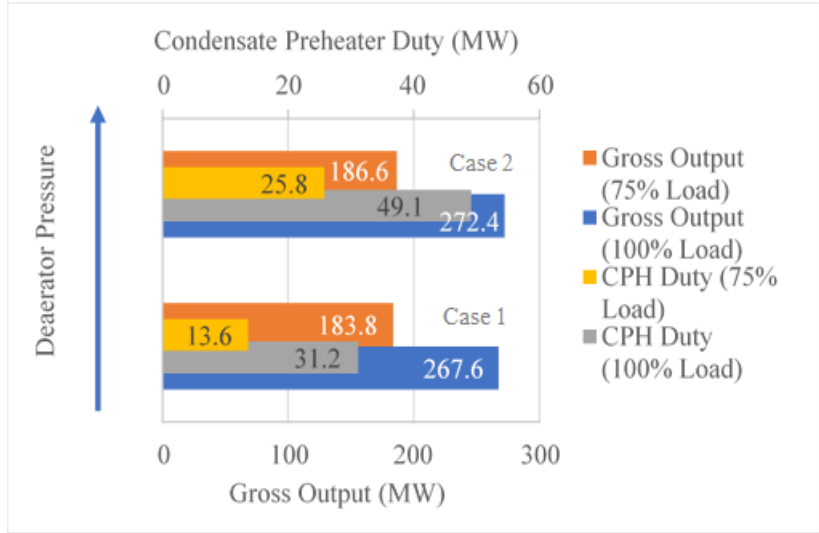

Figure 4. Effects on the Steam Cycle with Increasing Deaerator Pressure

Prior to the capture process, flue gas is cooled by a FGC to facilitate a reasonable approach between the circulating water and the cold condensate. This rejected heat is integrated back into the steam cycle via a CPH loop and eliminates the need for LP feed water heaters. At BD3, the intention was for FWH 1 and 2 remain fully out of service while CCS is on line. If the FGC comes off line the flue gas is diverted back to the stack, the capture island shuts down, but the power plant maintains operations with the LP FWHs out of service. The DEA must compensate for this loss in condensate preheating. This creates a differential pressure between the DEA and the turbine extraction which generates extreme flow velocity within the steam extraction line; this is unacceptable for continuous operation. To avoid this for Shand, three smaller CPHs were chosen and configured in series with LP FWHs 1 and 2 (Figure 2). The model of Case 2 was used as the basis of this optimization. The “cool” condensate was configured to flow from CPH1 to CPH 3 while the “hot” circulating water coming from the FGC was configured to flow from CPH3 to CPH1; enabling countercurrent flow. A trim cooler was also incorporated for removal of excess heat in the case of higher than usual flue gas temperatures. The CPH train loop was optimized by keeping a 5% duty on FWH 1 and 2 while ensuring a 15°C temperature rise across the DEA. FGC temperatures were modelled at 150°C, 175°C and 195°C to optimize the sizing of the three CPHs and the trim cooler as shown in Figure 5. Overall, heat integration provides excellent opportunities for utilization of waste heat. Optimization of this process can help decrease the associated output penalty.

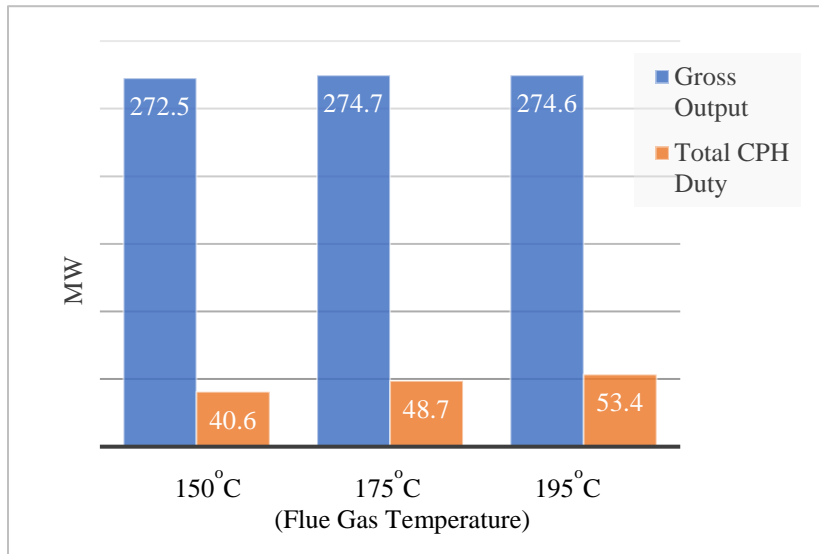

Figure 5. Comparing Gross Output and CPH Train Duty

Overall, heat integration provides excellent opportunities for utilization of waste heat. Optimization of this process can help decrease the associated output penalty.